

Maße für Druckkessel nach DIN 4810

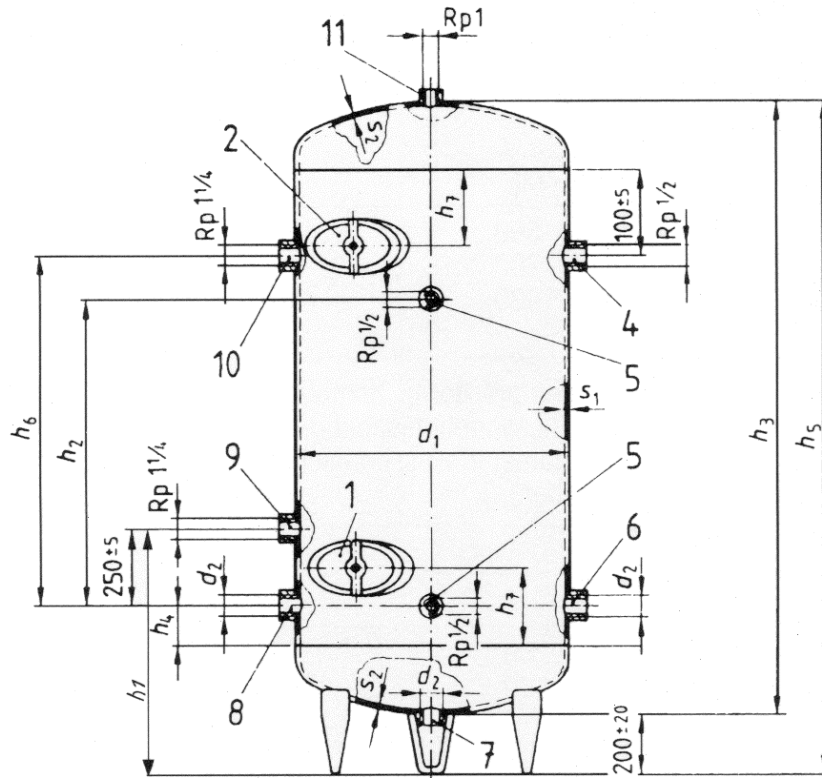

Anschlüsse:

- 1 - Handloch
- 2 - 2. Handloch (1000 l)
- 4 - Druckschalter
- 5 - Wasserstand
- 6 - Pumpe
- 7 - Entleerung
- 8 - Versorgung
- 9 - Entlüftung
- 10 - Belüftung

Typ	o mm	Höhe	Druck	Gewicht
150	450	1200	6	41
150	450	1200	10	51
300	550	1550	6	73
300	550	1550	10	92
500	650	1800	6	104
500	650	1800	10	149
750	800	1800	6	149
750	800	1800	10	197
1000	800	2300	6	184
1000	800	2300	10	247
1500	1000	2200	6	312
1500	1000	2200	10	395
2000	1100	2450	6	378
2000	1100	2450	10	508
3000	1150	3200	6	505
3000	1150	3200	10	692

Liter	d1	d2	h1	h2 +5	h3~	h4	h5	h6
150	450	R2	375	500	1000	200	1200	500
300	550	R2	400	700	1350	250	1550	675
500	650	R2	425	700	1600	250	1800	800
750	800	R2	475	700	1600	250	1800	800
1000	800	R2	475	1000	2100	300	2300	1050
1500	1000	R3	525	1000	2000	300	2200	1000
2000	1100	R3	575	1000	2250	450	2450	1125
3000	1150	R3	575	1000	3000	650	3200	1500

Handloch: 100*150mm
 2. Handloch ab 1500 Liter